

# VariFuel2/VariFuel2+

MOTORTECH Air/Gas Mixer



## General Information

# VariFuel2

MOTORTECH AIR/GAS MIXER

MOTORTECH's VariFuel2 is a high-tech variable Venturi type air/gas mixer that can constantly adjust to any fuel changes and allows the engine to operate at its most efficient point. Coupled to an air/fuel ratio controller, lean-burn or stoichiometric, it precisely regulates the mixture. The VariFuel2 is very popular for applications with constant changes in calorific value of fuel.

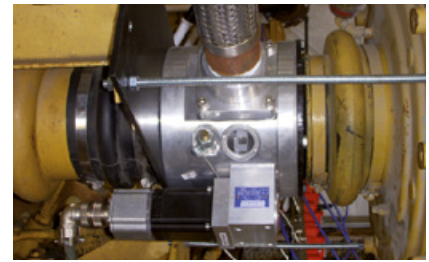

**NEW**

# VariFuel2+

MOTORTECH AIR/GAS MIXER

VariFuel2+ air/gas mixers are specially designed for use with natural gas-powered gas engines and are based on the general operating principle of the VariFuel2 series. The geometry of the built-in fuel ring, adapted to the application, ensures improved engine starting behavior and control of the air/gas mixture in natural gas operation.

VariFuel2 and VariFuel2+ air/gas mixer series 100, 140, 200, 250, 300 and 350 are available for engines with an air requirement up to 12,000 m<sup>3</sup>/h and are equipped with a high precision stepper motor which is extremely precisely actuated by the VariStep3 stepper motor driver. Different flow bodies and variable gas inlet and mixture outlet configurations allow flexible adaptation of the gas mixer to the respective application.

VariFuel2 and VariFuel2+ air/gas mixers are suitable for a wide range of gas types:

- Natural gas
- Biogas
- Landfill gas
- Sewage gas
- Wood gas
- Wellhead gas
- Mine gas



Series 200-120



Series 100-60



Series 140-80



Series 250-150



Series 300-190



Series 350-225

# Operating Principle

## Basic Design

The main task of a gas mixer is to mix the fuel (gas) and air in such a way that optimum combustion takes place in the gas engine. High efficiency and low emissions, in accordance with current regulations, are the decisive parameters for optimization.

In the VariFuel2, air and gas are mixed according to the Venturi principle. The air is sucked through the air intake into the Venturi nozzle by the suction vacuum of the engine. Due to the Venturi principle, a vacuum is created at the narrowest point, which sucks the gas through the gas inlet. In this way, gas and air are mixed and released at the mixture outlet.

Various mixer sizes and flow bodies **1** in the Venturi nozzle allow different volumetric flows to be achieved.

## Regulation of the Air/Fuel Mixture

The fuel (gas) is guided into the nozzle via the adjustable openings **2** in a fuel ring **3**. The openings of the fuel ring are adjusted by a drive belt **4** via a stepper motor. The stepper motor **5** can be controlled by the VariStep3 stepper motor driver, which can process the signals of a master control.

In addition, the VariFuel2 air/gas mixers are equipped with a port for an air pressure gauge and a connection for the pulse line of a zero pressure regulator.

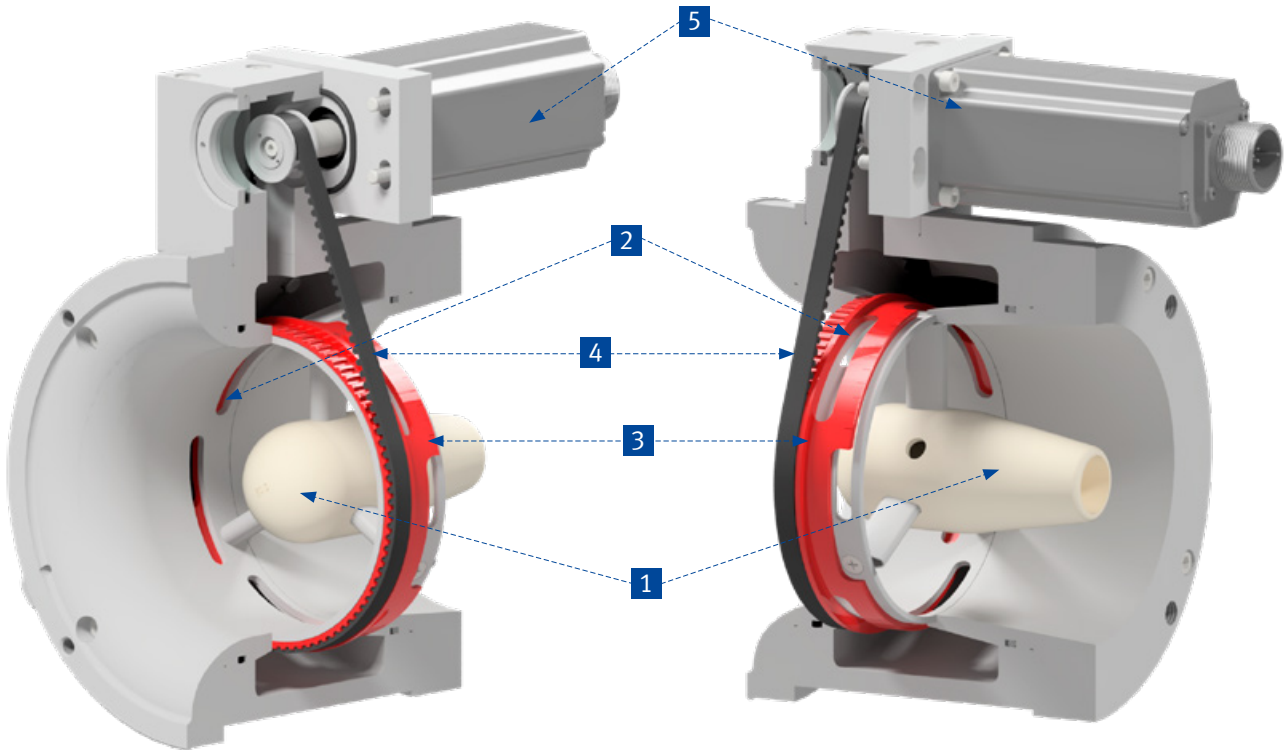

# Operating Range



Scan the QR code® to download the specification table to specify a suitable air/ gas mixer for your application.

## Features

VariFuel2/VariFuel2+ Series	100-60	140-80	200-120	250-150	300-190	350-225
Air requirement	100 to 650 m³/h	200 to 1,300 m³/h	500 to 3,200 m³/h	1,800 to 5,200 m³/h	3,400 to 8,500 m³/h	6,000 to 12,000 m³/h
100						
250						
500						
750						
1,000						
1,250						
1,500						
1,750						
2,000						
2,500						
3,000						
3,500						
4,000						
4,500						
5,000						
5,500						
6,000						
6,500						
7,000						
7,500						
8,000						
8,500						
9,000						
9,500						
10,000						
10,500						
11,000						
11,500						
12,000						
Available flow body sizes	23.0 to 55.0 mm in steps of 2.5 mm	23.0 to 72.5 mm in steps of 2.5 mm	23.0 to 107.5 mm in steps of 2.5 mm	23.0 to 110.0 mm in steps of 2.5 mm	35.0 to 140.0 mm in steps of 5.0 mm	35.0 to 150.0 mm in steps of 5.0 mm
Flexible inlet and outlet configuration	x	x	x	x	x	x
Driven by timing belt	x	x	x	x	x	x
Number of gas pressure gauge connections	1	1	1	1	1	1
Number of air pressure gauge connections	1	1	1	1	1	1
Hose connection for air inlet	x	x	x	x	x	x
Various flange connections for outlet	x	x	x	x	x	x
Various flange connections for gas inlet	x	x	x	x	x	x
The central flow body is fixed with 3 profiles. Their numerous small gas inlets provide an optimum mixture of gas and circulating air, granting a constant level of homogenization of the air-gas mix.	x	x	x	x	x	x

## Accessories



Example for mounting on MAN® E3262 LE gas engine.



### 2 Flow Bodies

Depending on the application, suitable flow bodies in different sizes are used to influence the flow velocity.

- Flow bodies are made of aluminum and, from a diameter of 60 mm, of high-strength thermoplastic material.

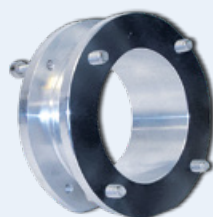

### 3 Outlet Flange Kits

Outlet flanges for easy connection of the VariFuel2/ VariFuel2+ air/gas mixers to typical gas engines.

- Standard and engine-specific types are available.



### 4 Gas Inlet Flanges

Gas inlet flanges for connecting the gas train to the VariFuel2/VariFuel2+ air/gas mixer.

- Versions with different thread sizes are available for each gas mixer series.



### 5 Stepper Motor Harnesses

Harnesses for connecting the stepper motor to the VariStep3 stepper motor driver.

- Different versions are available with 10 pole MIL connector for reliable connection to the stepper motor.



## Accessories

# VariStep3

MOTORTECH STEPPER MOTOR DRIVER

## 6 VariStep3 – Stepper Motor Driver

The stepper motor driver developed by MOTORTECH guarantees the ideal control of the various types of MOTORTECH VariFuel2 and VariFuel2+ air/gas mixers.

### Features

- Precise mixer adjustment due to microstep operation
- Very fast response times
- Accelerated reference run
- LEDs displaying unit status and activity Combination of several units without signal amplifier/splitter
- Integrated CANopen and Modbus RTU interface
- Configuration via MICT software
- Error data logging for improved diagnostic options
- Compact design
- Plug-in terminals
- Easy access to connectors and switches
- Switch board installation on DIN rail



# MICT

MOTORTECH INTEGRATED CONFIGURATION TOOL

The MICT is the graphical user interface for the VariStep3 stepper motor driver. All functions of the VariStep3 are user programmable and can be displayed individually.

### Features

- Language selectable (DE/EN/CN)
- Microsoft® Windows XP/Vista/7 compatible
- Print function of a snap-shot in the operation can be used for external problem analysis, etc.
- Context sensitive online help
- Different access levels to avoid accidental misconfigurations

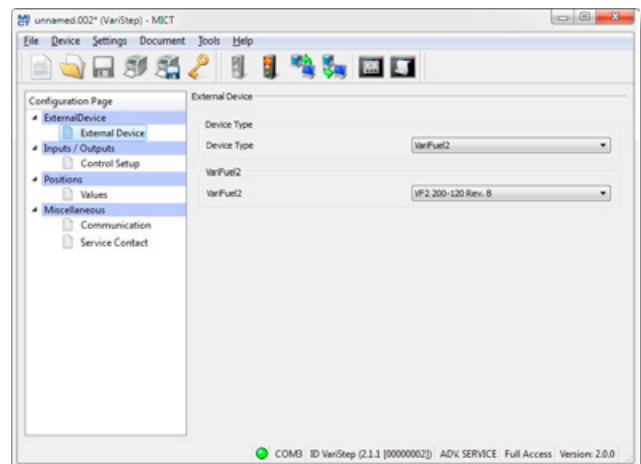

# System Overview



## VariFuel2/VariFuel2+

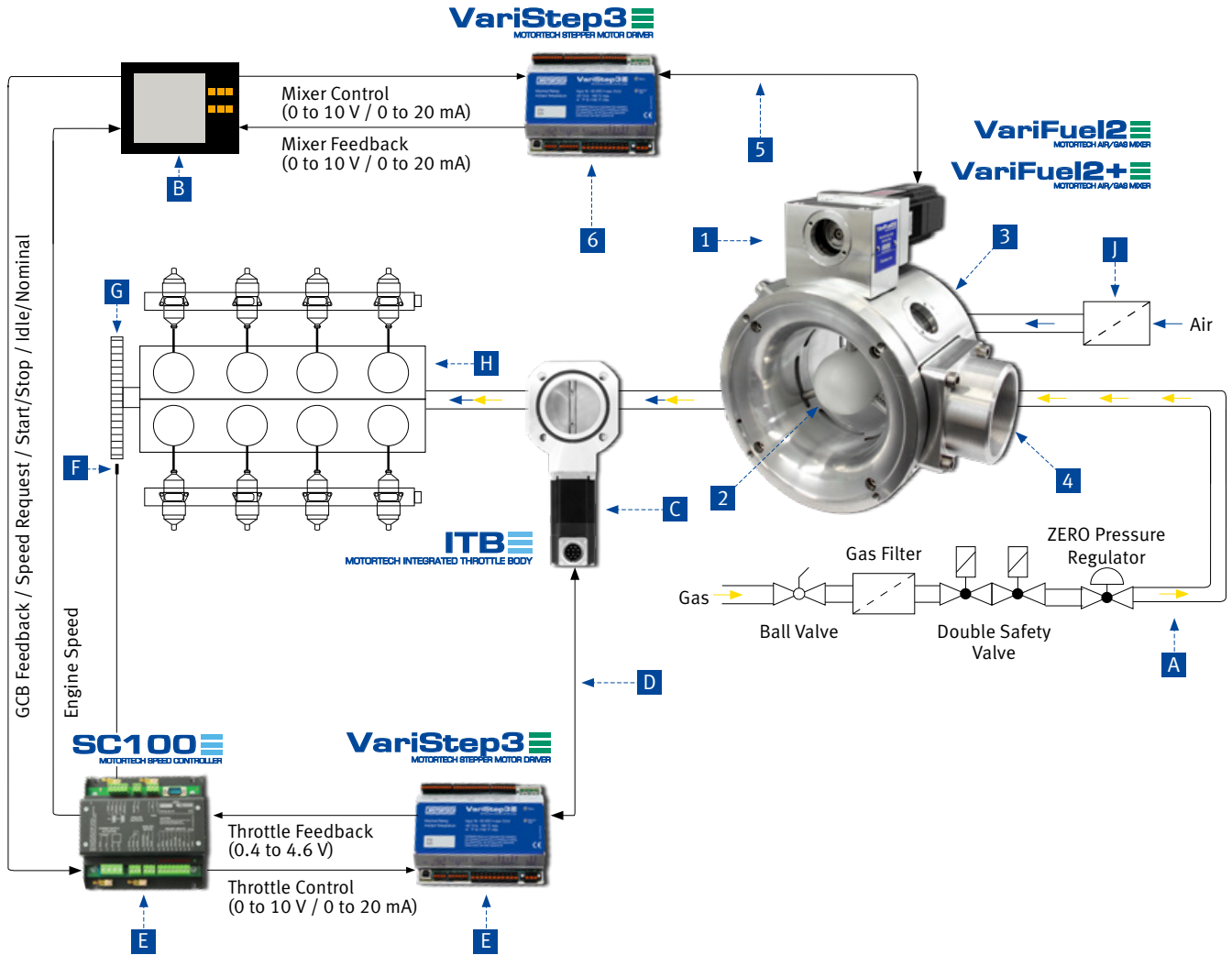

### Required Accessories

- 1 VariFuel2/VariFuel2+ air/gas mixer
- 2 Flow body
- 3 Outlet flange
- 4 Gas inlet flange
- 5 Stepper motor harness
- 6 VariStep3 stepper motor driver

### Description

- A Gastrain (ZERO Pressure Regulator required)
- B Master control/Emission control system
- C ITB throttle body with integrated stepper motor
- D Stepper motor harness
- E Speed control kit incl.
  - VariStep3 stepper motor driver
  - SC100 speed control
- F Magnetic pickup
- G Flywheel
- H Engine
- J Air filter

# VariFuel2-TEM

**NEW**

## VariFuel2-TEM Air/Gas Mixer For **MWM**® TCG 2016 V08 C, V12 C and V16 C Gas Engines

The VariFuel2-TEM air/gas mixer is based on the proven design of the VariFuel2 series and is specially designed for use with MWM® gas engines. Designed as a replacement and plug-and-play solution for the gas mixers used on the TCG 2016 series, the VariFuel2-TEM easily fits into the existing engine structure without any mechanical modifications.

In addition to full compatibility, both mechanically and in connection with existing TEM controllers, the VariFuel2-TEM contributes to an improvement of the starting behavior and mixture control via its variable fuel ring and enables low-maintenance operation over a long period of time.

### Features

- Plug-and-play solution for easy replacement of the original gas mixer without mechanical modifications or cabling adjustments
  - 1 Suitable flanges for direct connection to existing intake manifold, suction hose and gas train
  - 2 Stepper motor with connecting cable and mating connector to multifunction rail
  - 3 Position sensor suitable for cabling of the multifunction rail
- Direct control by existing TEM management system
- The variable fuel ring of the VariFuel2-TEM improves the mixture control behaviour and thus enables an optimized starting behaviour and performance, especially in operation with special gases
- Low-maintenance part reduces operating costs by saving expensive repair kits





## VariFuel2-TEM

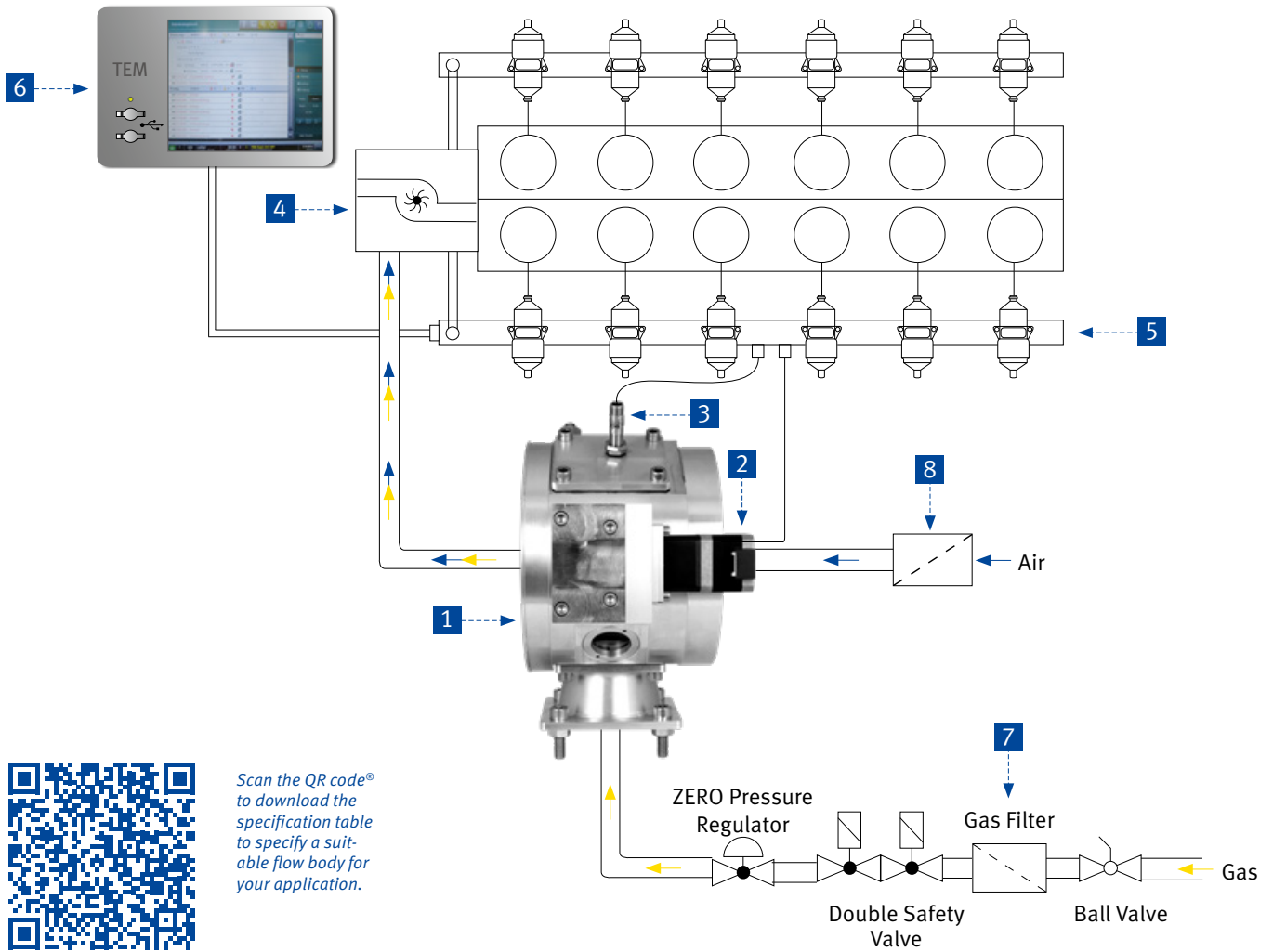

Scan the QR code® to download the specification table to specify a suitable flow body for your application.

### Description

- 1 VariFuel2-TEM air/gas mixer
- 2 Stepper motor with connecting cable and connector
- 3 Position sensor
- 4 Turbo charger
- 5 Multifunction rail
- 6 TEM management system
- 7 Gastrain
- 8 Air filter

## Service & Accessories

### Repair and Overhaul Service for VariFuel2 and VariFuel2+ Air/Gas Mixers

MOTORTECH offers a flat rate program for the repair and overhaul of the VariFuel2 air/gas mixers. Sent gas mixers are completely dismantled during the revision process and all components are thoroughly cleaned and tested.

During subsequent assembly, defective or worn components are replaced. A final function test and a leakage test guarantee further faultless operation for a long time. As part of plant maintenance, this service is also available for functioning gas mixers to ensure continued operation.

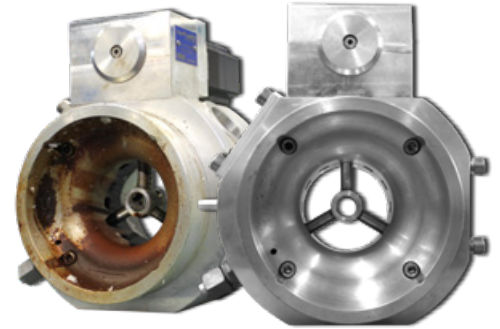

#### 1 Isolation Amplifier

Using the isolation amplifier, the position signal of an EmCon5 emission controller can be passed to a second VariStep3 stepper motor driver. This way two VariFuel2 air/gas mixers can be controlled with one EmCon5 emission controller on a V-engine.

#### 2 Test Kit for Commissioning

When performing a test run on the test bench or commissioning a new engine, it can be necessary to replace the flow body with one of another size in order to achieve perfect results. The test kit has been put together specifically for commissioning technicians and employees working on test benches, and offers a wide selection of all common flow bodies for successful commissioning.

### Tools for Repair & Maintenance

To simplify repair and maintenance work, MOTORTECH offers special tools for the air/gas mixers of the VariFuel2 family.

#### 3 Adjustment Tool for Belt Tension

To ensure the best possible air/fuel ratio, the belt tension must be adjusted every time the drive belt is replaced or after any changes that may impact the tension of the drive belt. The tool specially designed for each air/gas mixer type enables comfortable adjustment of the optimum belt tension.

#### 4 Locking Tool for Toothed Pulley

The tool is used for locking the toothed pulley of an air/gas mixer, to tighten or release the hexagon socket head cap bolt that fixes the toothed pulley on the shaft. These work steps are for example necessary for adjusting the fuel ring or replacing the toothed pulley.

#### 5 Tool for Inspection Window or Maintenance Cap

The tool is used to install and remove the inspection window or maintenance cap at the upper part of the air/gas mixer housing. The inspection window or maintenance cap need to be replaced, for example, if access to the toothed pulley is needed.

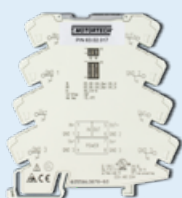

1



2



3



4



5

## Repair Kits

Regular maintenance is necessary to ensure the flawless operation of the VariFuel2 air/gas mixer at all times. Besides the recommended factory overhaul, MOTORTECH also offers a range of repair kits that are specifically tailored to the various VariFuel2 and VariFuel2+ series and which include all the components for the relevant repairs.



## Dimensioning Data Sheet for VariFuel2/VariFuel2+/VariFuel2-TEM Air/Gas Mixers

For the correct air/gas mixer layout, please fill in the following dimensioning data sheet and send it to MOTORTECH or your nearest MOTORTECH sales Partner:

Engine manufacturer	Series	Engine model	
Number of Air/Gas Mixers	<input type="checkbox"/> One single Air/Gas Mixer <input type="checkbox"/> Two separate Air/Gas Mixers (one mixer per bank)		
Flange size air intake	Flange size outlet	Flange size gas inlet	
Stroke	<input type="checkbox"/> 2 stroke <input type="checkbox"/> 4 stroke		
Number of cylinders			
Cylinder arrangement	<input type="checkbox"/> Inline Engine <input type="checkbox"/> V Engine		
Bore x stroke		Displacement	
Engine type	<input type="checkbox"/> Turbocharged engine <input type="checkbox"/> Naturally aspirated engine		
Intercooler	<input type="checkbox"/> Yes <input type="checkbox"/> No		
Nominal speed			
Engine power (kW)	kW value	<input type="checkbox"/> Mechanical <input type="checkbox"/> Electrical	
Fuel			
Calorific value of fuel (kWh Nm <sup>3</sup> ) (or gas analysis)			
Fuel consumption (Nm <sup>3</sup> /h) (data sheet)			
Air consumption (Nm <sup>3</sup> /h)			
AFR Lambda at full load			
Turbo pressure at full load			



Scan the QR code<sup>®</sup> to download the specification table to specify a suitable flow body for your application.

## Download now!



### All Products at a Glance!

For further Information about the MOTORTECH products get our product guide online.



Scan QR-Code to get to the download page

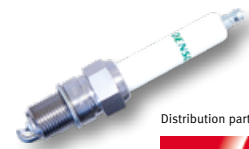

Distribution partner for DENSO spark plugs



Scan QR-Code to subscribe



### Once a month the latest news!

Subscription also at [www.motortech.de/subscribe.html](http://www.motortech.de/subscribe.html) or send a short request via email: [direkt@motortech.de](mailto:direkt@motortech.de)

#### **MOTORTECH GmbH**

Hogrevestr. 21-23  
29223 Celle  
Germany  
Phone: +49 (5141) 93 99 0  
Fax: +49 (5141) 93 99 99  
[www.motortech.de](http://www.motortech.de)  
[sales@motortech.de](mailto:sales@motortech.de)

#### **MOTORTECH Americas, LLC**

1400 Dealers Avenue, Suite A  
New Orleans, LA 70123  
USA  
Phone: +1 (504) 355 4212  
Fax: +1 (504) 355 4217  
[www.motortechamericas.com](http://www.motortechamericas.com)  
[info@motortechamericas.com](mailto:info@motortechamericas.com)

#### **MOTORTECH Shanghai Co. Ltd.**

Room 1018 Enterprise Square,  
No. 228 Meiyuan Road,  
Zhabei District, 200070 Shanghai  
China  
Phone: +86 (21) 6380 7338  
[www.motortechshanghai.com](http://www.motortechshanghai.com)  
[info@motortechshanghai.com](mailto:info@motortechshanghai.com)

P/N 01.55.002-EN | Rev. 03/2018 | VariFuel2/VariFuel2+ MOTORTECH Air/Gas Mixer

#### **Copyright**

The copyright for all materials used in this MOTORTECH publication is reserved. Any kind of duplication or use of objects such as pictures or texts in other electronic or printed publications without approval by MOTORTECH is not permitted.

#### **Trademark Information**

MOTORTECH products and the MOTORTECH logo are registered and/or common law trademarks of MOTORTECH GmbH.

All OEM names and part numbers shown are for reference purposes only. All trademarks, logos and symbols used or shown in this MOTORTECH publication are exclusive objects to the right of their owners and are used for reference purposes only.

Distribution: