

I Throttle Body

P/N 30.41.150-D-HT, P/N 30.41.155-D-HT

Variations

- Standard diameters D of the throttle (*see drawing*) 90 mm (3.54"), 100 mm (3.94")
- Possible diameters of the throttle 82 mm (3.23") to 104 mm (4.09")

Dimensions

- Length/width of mounting flange 148.7 mm (5.85")
- Hole spacing on the mounting flange 110 mm (4.33")
- Height of mounting flange 80 mm (3.15")

Gasket (P/N 30.41.150-D-HT only)

- Type O-ring
- Inside diameter 116 mm (4.57")
- Cross section 3 mm (0.12")

Weight

- P/N 30.41.150-90-HT, P/N 30.41.155-90-HT 2.2 kg (4.85 lbs)
- P/N 30.41.150-100-HT, P/N 30.41.155-100-HT 2.0 kg (4.41 lbs)

Mechanical Data

- Maximum rotation angle of the throttle 80°
- Chemical resistance Water, oil, gaseous fuels
- Absolute pressure 4.5 bar (65 psi)
- Maximum temperature of media flowing through +200 °C (+392 °F)

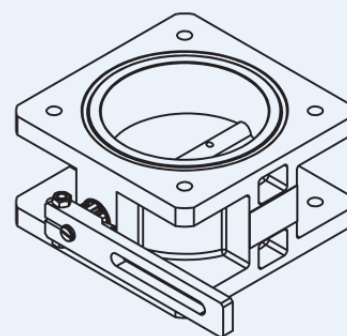

Overview Drawing

P/N 30.41.150-D-HT

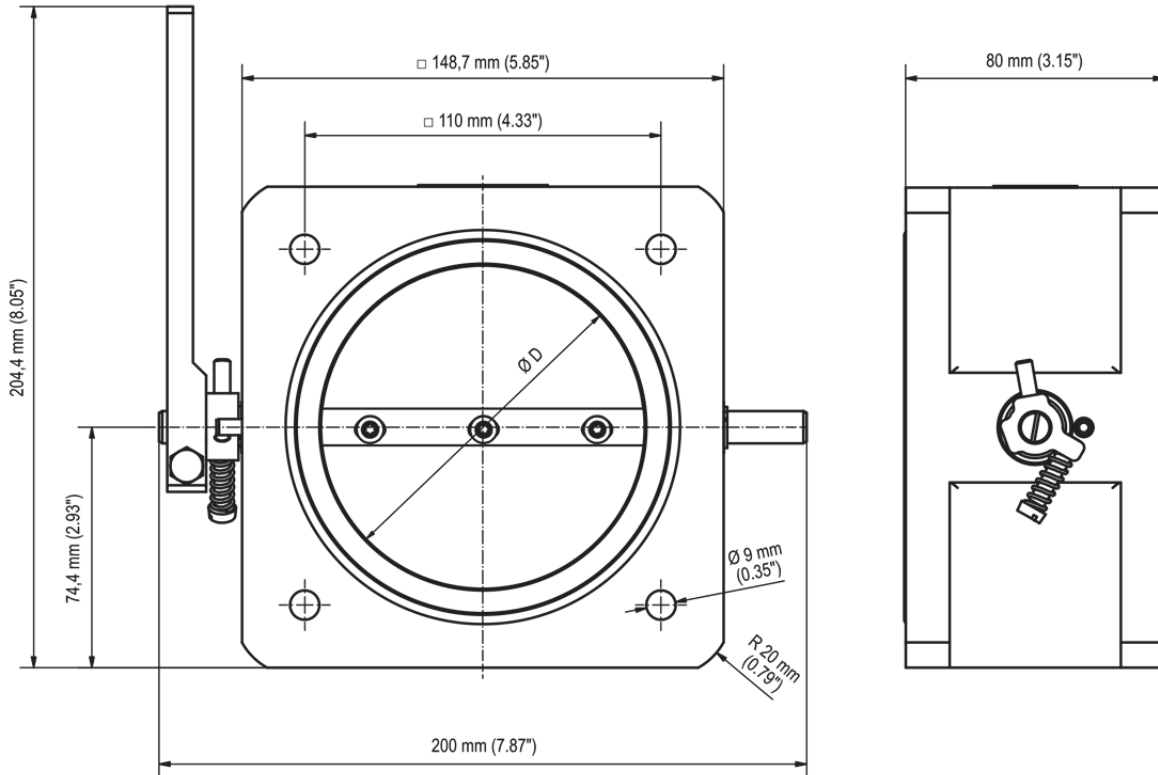

P/N 30.41.155-D-HT

